



**CITY OF HAWAIIAN GARDENS**  
**DEPARTMENT OF COMMUNITY DEVELOPMENT**  
**BUILDING AND SAFETY DIVISION**  
 21815 Pioneer Boulevard  
 Hawaiian Gardens, Ca 90716  
 (562) 420 2641

**A-007**

**EFFECTIVE :**  
**1-05-2015**

**ACCESSIBILITY DETAILS FOR CURBS AND RAMPS**

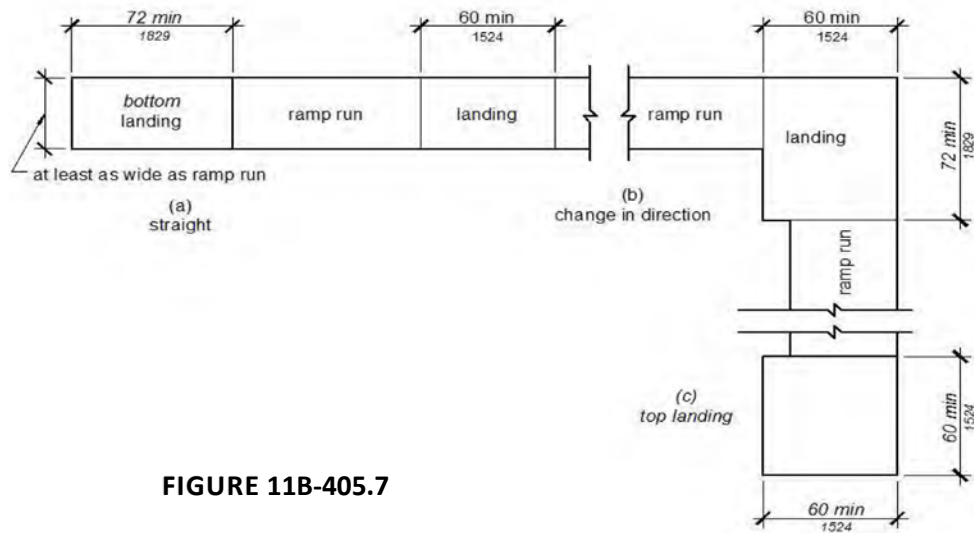

**FIGURE 11B-405.7**  
**RAMP LANDINGS**

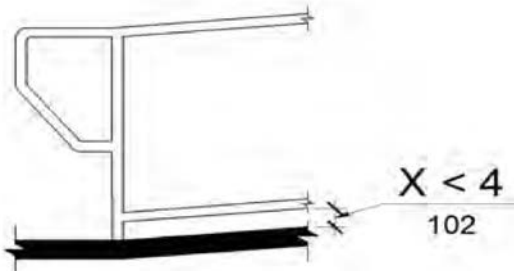

**FIGURE 11B-405.9.2**  
**CURB OR BARRIER EDGE PROTECTION**

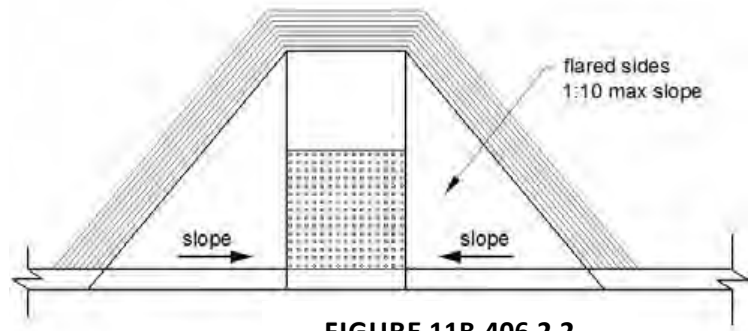

**FIGURE 11B-406.2.2**  
**SIDES OF CURB RAMPS**

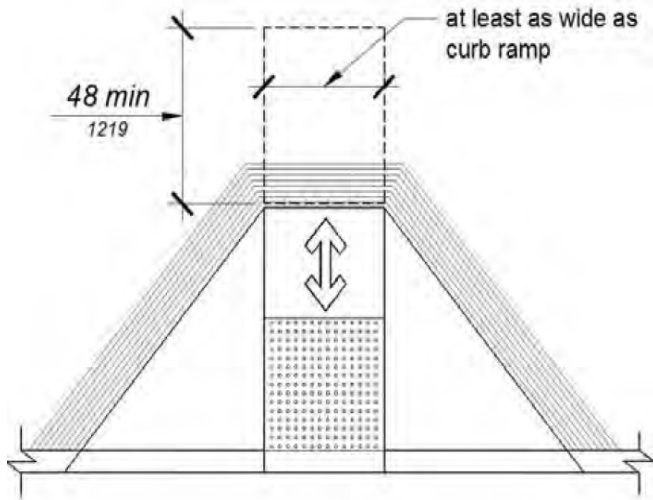

**FIGURE 11B-406.5.3**  
**LANDINGS AT THE OF CURB RAMPS**

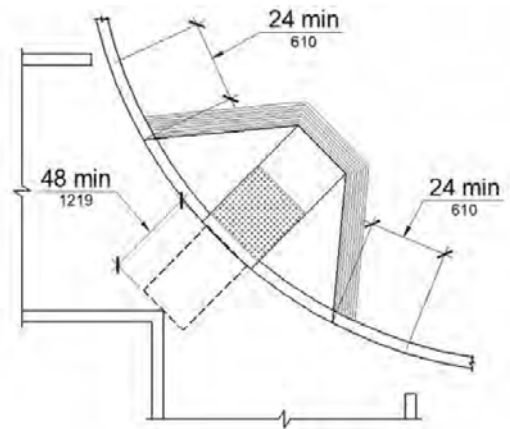

**FIGURE 11B-406.5.10**  
**DIAGONAL OR CORNER TYPE CURB RAMPS**

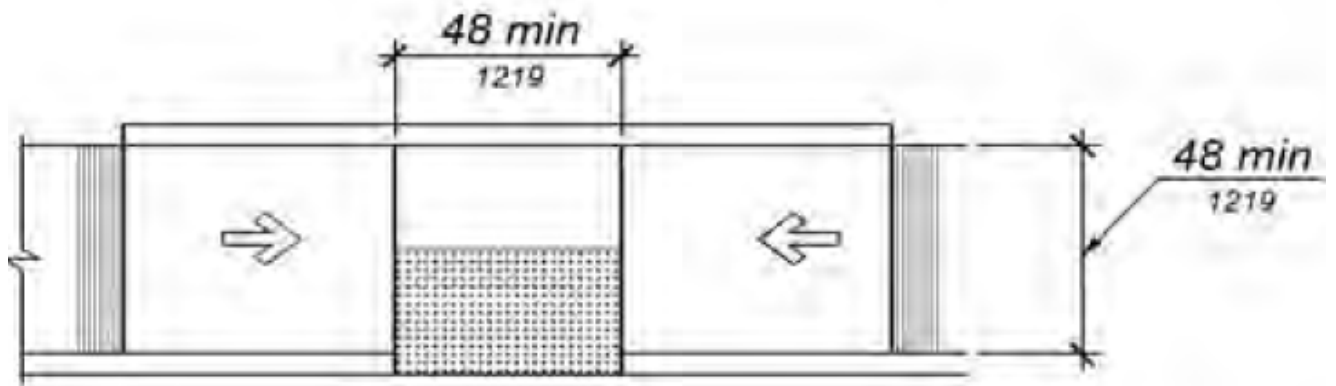

**FIGURE 11B-406.3.2**  
**PARALLEL CURB RAMPS**